

# CIRCUIT CELLAR **ONLINE**

## THE MAGAZINE FOR COMPUTER APPLICATIONS

*Circuit Cellar Online* offers articles illustrating creative solutions and unique applications through complete projects, practical tutorials, and useful design techniques.

[This Month](#)
[Archive](#)
[About Us](#)
[Contact](#)
[Looking for More?](#)

## RESOURCE PAGES

### RESOURCE LINKS

A Guide to online information about:

**Solid-State Relays**

by [Bob Paddock](#)

---

This month, an [AskUs](#) question lead me to attempt to find the perfect switch, exactly the type of component that would go well with the [Perfect Battery](#) (Fuel Cells and Radiological Heater Units) that I've covered in the [past](#).



The perfect switch should have the following attributes:

- [zero resistance](#) in the "on" state
- infinite impedance when in the "off" state
- can handle infinite current
- no minimum hold current.
- can handle a signal of infinite bandwidth
- is totally independent of temperature effects at anything above absolute zero
- an infinite life span.
- opens and closes instantly with zero arcing at any voltage from zero to infinity

As you've probably figured by now, you will not find one unless you settle for something like a [super-conductor](#) (The NIST WWW High Temperature Superconductors database (WebHTS) provides evaluated thermal, mechanical, and superconducting property data for oxide superconductors.), and that's not practical at this moment in time. Because sometimes those "worst case" specs on the datasheets are a reality, it's never a good idea to design for the elusive perfect anything. Singling out any part for perfection will lead to nothing but headaches. See [Beware: Worst-Case Specifications Can Be a Reality](#) by Steve Hobrecht at [Linear Technologies](#).

One practical avenue you can take to find the perfect switch is solid-state relays (SSRs).

The biggest imperfection of most any solid state switch is false turn on. That is, the switch turns itself on without a signal commanding it to turn on at that time. This typically is a problem when driving inductive loads. The typical solution to prevent false turn on is to use a "Snubber" circuit. But, I'll cover Snubbers in a separate [Resource Page](#).

---

[Maxim](#) has a paper ([How to Select the Right CMOS Analog Switch](#)) that should point you in the right direction if you are looking to control low-level signals. However, in this [Resource Page](#), I'll concentrate more on power-level switches.

---



An in-a-nut-shell introduction to ["Industry Standard" Solid-State Relays and Mounting Racks](#) can be found at [Industrologic, Inc.](#)

---

You can build your own SSR by using parts from [International Rectifier](#) and [Supertex](#).

[IRF's AN-1015](#), *The PVI: A Versatile Circuit Element* shows a unique application of their Photovoltaic Isolator. By using the IRF PVI along with [Supertex's](#) DN25 series depletion mode FETs (this type of FET is normally "on," versus the more common kind type that is normally "off") you get closer to that mythical perfect switch. See [Application Note AN-D18, "High Voltage Regulators and Linear Circuits using DN25"](#).

## Solid State Relay

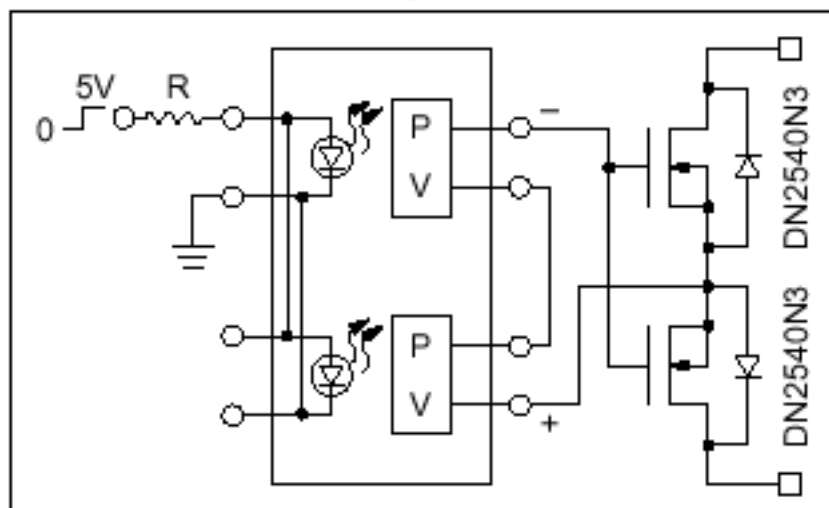

- Normally on
- $\pm 400\text{V}$  blocking
- Low  $C_{IN}$  for fast switching

Telecommunication, instrumentation, fax machines, modems,  
data line diagnostics

If you don't want to build your own, you can pick up a ready-made one from Agilent in their [HSSR-8400, 400 V/10-ohm, General-Purpose, 1 Form A, Solid State Relay](#) or one of [International Rectifier's](#) own Microelectronic Relay (MER) replaces for Mercury-wetted reed relays.

The [PVX6012](#) is a single-pole, single-throw, normally-open (1 Form "A") relay using a pair of inverse-series-connected IGBTs to form the output switch. Parallel to each of the two IGBTs is a FRED (Fast Recovery Epitaxial Diode) allowing low-voltage-drop conduction in the reverse polarity.

The [PVT442](#) is a specialized telecom microelectronic relay with single-pole, single-throw, and normally-closed (otherwise referred to as 1 Form B) contacts. Its intended use is in peripheral telephone equipment where a connection to the telephone line is required during power outages. It might be worth a look for your application.

[AN-101](#): Choosing an Input Resistor for a Microelectronic Relay is something you'll need to look at, also.

Just as a brief "aside," I find it interesting that [IRF](#) is pointing out how [bad Mercury has become for the environment](#), yet thousands of dentist put pounds of Mercury in our mouths everyday in the form of fillings, or say even the vaccines with [mercury-containing preservative thimerosal](#) we give our children. For some reason, Mercury is not considered toxic waste as long as it is in your body. Do you see a problem with this picture? As someone suffering from Mercury poisoning I agree with IRF myself.

---

Because SSR inputs are almost universally LEDs, it would be a good idea to review some of the application notes related to LED drivers.

[Agilent Technologies optocouplers](#) can be used in an array of isolation applications, ranging from power supply and motor control circuits to data communication and digital logic interface circuits.

Agilent's [Designer's Guide to Isolation Circuits](#) is a 82-page book that contains 50 application circuits. The handbook begins with a section discussing critical optocoupler design parameters such as insulation and withstand voltage, regulatory agency safety standards, common-mode transient rejection, product life, and light emitting diode (LED) aging.

Marktech Optoelectronics' book [LED Driver Application Notes](#) covers the history of the LED to pulsed applications.

[Sharp Microelectronics of the Americas](#) has numerous [applications notes](#) related to LED's and LED drivers.

---

### [COMPARISON OF SOLID-STATE RELAY TYPES](#)

The type of solid-state relay used in an application depends upon the load to control. Click on the links below to compare each type and to learn more about situations where they are used.

[Zero Switching](#)  
[Instant ON](#)

[Peak Switching](#)  
[Analog Switching](#)

The above is part of [Cutler-Hammer University](#). If you're new to the field, it offers the [101 Basics Series](#) that will greatly improve your understanding of the products involved in distributing, controlling, and using electricity. The Cutler-Hammer 101 Basics Series is a self-directed, distance learning program comprised of a number of different modules. Each module focuses on a specific product group. The 101 Basics Series is designed to establish a solid foundation understanding of the products manufactured by Cutler-Hammer and will prepare you for subsequent classroom and distance learning courses. Often, the 101 Basic Series or specific modules within the series are required as prerequisites for intermediate and advanced Cutler-Hammer courses.

---

You can take a look at the concepts for [Analog Devices Micromachined Relays](#). How would you like a 16-poll relay in a BGA package (7.5 x 7.5 x 1.0 mm)? They are looking for people to give them ideas and applications. Products based on the  $\mu$ mRelay technology will not be available until mid-to-late 2001.

Although definition of the initial  $\mu$ mRelay product has not been finalized, it will likely be similar to the product described below. Follow-on products will provide increased integration with various switch/relay counts, as well as the inclusion of other semiconductor functions.

Initial Product Concept: 16-channel high-density switch

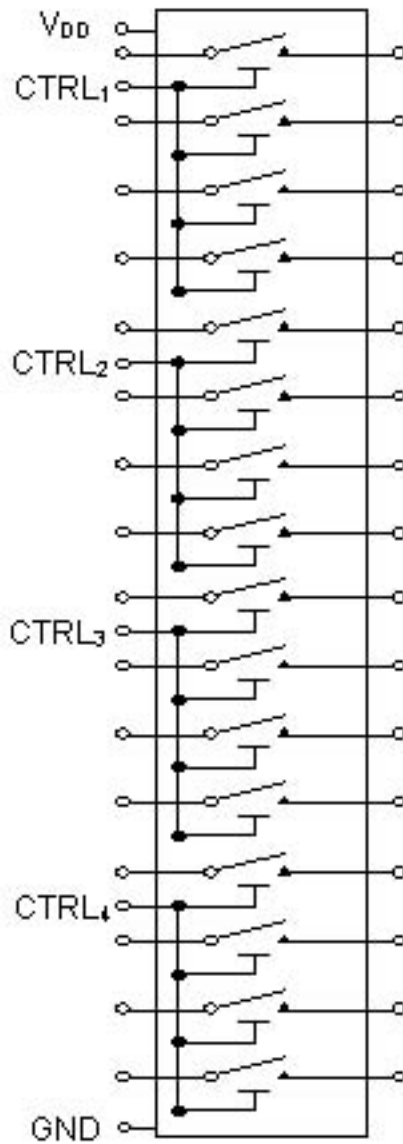

BGA package (7.5 x 7.5 x 1.0 mm)

Power consumption\*: 0.3 mW max.

On resistance: 0.5 ohms max.

Input-output capacitance: 50 fF max.

Maximum input voltage: 150 V min.

Maximum carrying current: 1 A (average) min., 5 A (peak) min.

Switching time: 6  $\mu$ s max.

-3-dB bandwidth: 2 GHz. min.

Mechanical and electrical lifetime\*\*:  $10^9$  cycle min.

Budgetary pricing: <\$16 (<\$1 per switch)

\* Power consumption is proportional to the switching frequency.

[Aromat](#) is part of [Matsushita Electric Works, Ltd. \(MEW\)](#) in Osaka, Japan. They make old-fashion, heavy, metal relays, as well as their [PhotoMos Relays](#).



**NAIS<sup>®</sup> PhotoMos Relays**

One gripe I have about their [home page](#) is that it is over 650K, a real pain when all you have is a dial-up connection. I almost didn't include them here because I was tired of waiting for it to load.

---

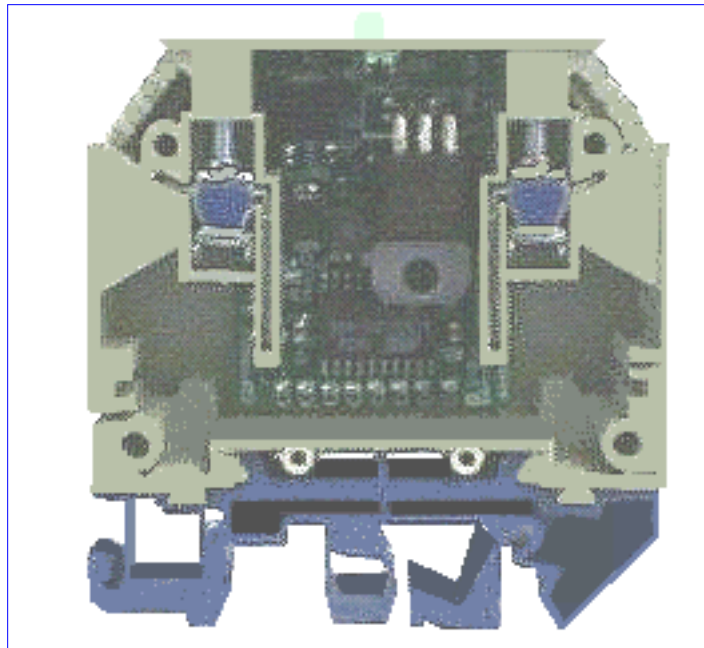

[Axiomatic Technologies'](#) line of solid-state relays includes the following products:

- [Solid-State Timed Relay](#)
- [Low-Current Solid-State Relay](#)
- [Solid-State Relay with Turn-On Delay](#)

The [timed relay](#) permits any digital function to be performed on the single output. The device is typically delivered fully configured from the factory. No programming is required by the customer. Depending on the complexity of the task involved and the number of units ordered, there may be an initial factory configuration charge if the function is not already listed in the appendix. An inexpensive programming system is

available for those wishing to program the device in-house. Field programming from a laptop is also possible.

[Solid state relay with turn-on delay](#) is designed to accept standard input voltages of 24 VDC or 129 VDC. The relay provides for a 3-ms time delay to prevent accidental short pulses from activating the relay. It was originally designed for electrical substation applications.

---

[California Eastern Laboratories](#) is [NEC's](#) authorized North American source for photocouplers, solid-state relays, and optoelectronic devices.

**NEC is one of the largest producers of photocouplers and optocouplers. These devices offer IC output, high-speed output, SCR output, high-voltage transistor output and hybrid devices in DIP, SOP, and SSOP packages.**

Several design tips can be found in [Optocoupler Applications.pdf](#).

---

OptoMOS® products were the first optically coupled MOSFET devices for any telecom application. However, there are many other applications where [Clare's](#) OptoMOS® devices may provide a solution for design requirements.

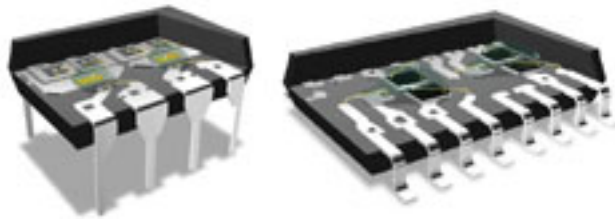

[Clare](#) has [several styles of SSRs](#), including:

- single pole (4 pin) world's smallest relay
  - single pole (6 pin) one relay in a 6-pin package
  - dual pole two independent relays in a single package
  - common input (single input controlling dual output)
  - multifunction telecom switch integrated relay and optocoupler
  - integrated products relay, optocoupler, and other integrated functionality
  - linear optocouplers/linear isolation amplifiers
-



Continental Industries has several helpful hints on applying SSRs.

"Adequate heat sinking, including consideration of air temperature and flow, is essential to the proper operation of a solid state relay (SSR). It is necessary that the user provide an effective means for removing heat from the SSR package. The importance of using a proper heat sink cannot be over stressed because it directly affects the maximum usable load current and/or maximum allowable ambient temperature. Lack of attention to this detail can result in improper switching (lockup) or even total destruction of the SSR. Up to 90% of the problems with SSR's are directly related to heat."

- [Heat sinks and SSRs](#)
- [Protective Measures/Electrical Noise](#)
- [Surge Ratings](#)
- [Fusing](#)
- [SSR Applications](#)

They even give you nice clear schematics of what the modules do, I wish more of the web pages I saw when making this Resource Page did that. Sometimes there were tables full of descriptions that still left you wondering what was different between Device-A and Device-B.



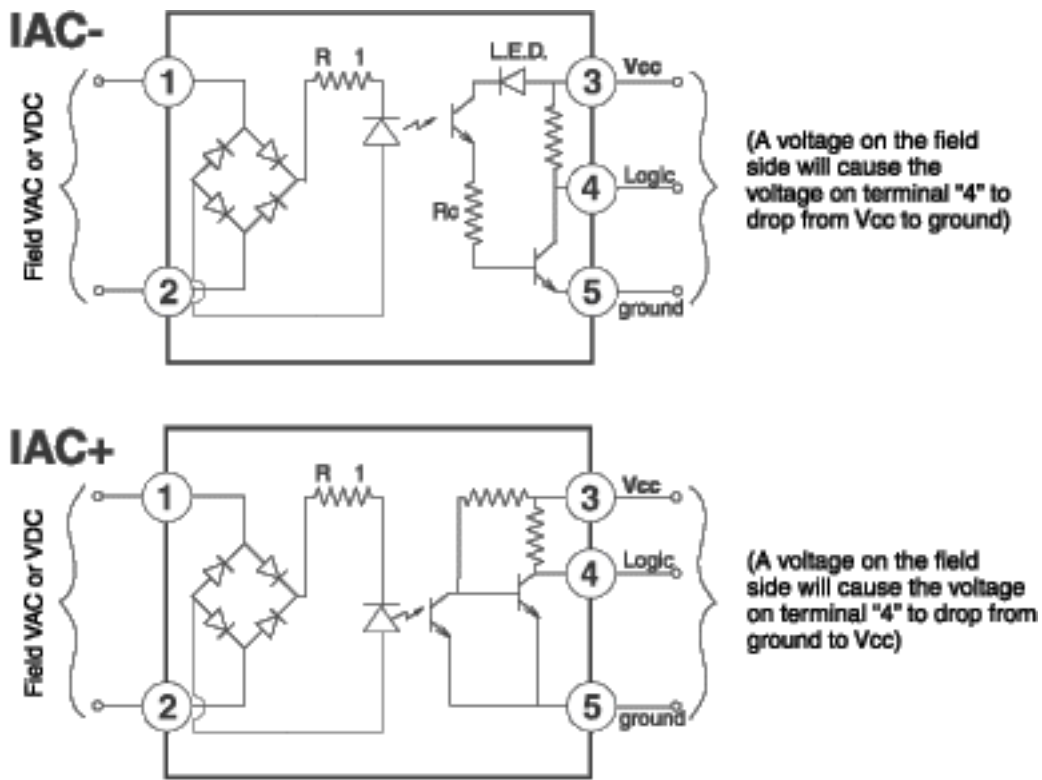

Their product line ranges from 4 to 100 A/660 VAC, with special inputs (such as 4–20 mA or 0–10 V) available on some models.

**Products & Services****Solid State Relays**

PCB Mount

Panel Mount

Aux. Function  
ModulesPower  
Modules

I/O Modules

DIN Rail

**Transient Voltage  
Suppression**

In the early 1970s, [Crydom](#) designed, patented, manufactured, and created the world's industry-standard solid-state relay (SSR). Since then, Crydom has maintained its leadership position as demonstrated by its introduction of innovative products such as multi-pole devices, high-power printed circuit board mount types, and with still more to come. Of the 1,000+ products, a good portion are of custom design (that is, developed in conjunction with OEMs wanting to meet the requirements of specially designed systems and equipment). Crydom manufactures over 1,000 different models of SSRs, as well as a broad range of thyristor/diodes, I/O modules, and transient voltage suppressers (TVS). Crydom has an extensive range of SSRs, from 1 to 150 A, in industry-standard designs and mounting options.



[A Prime Technology Company](#)

[High Reliability DC Control Relays](#)

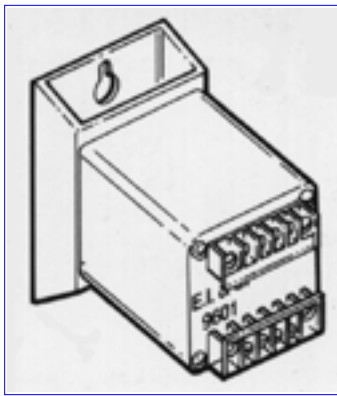

AC Input, DC Output (MOSFET)  
Fail-safe output protection circuitry

### DC Input/AC Output

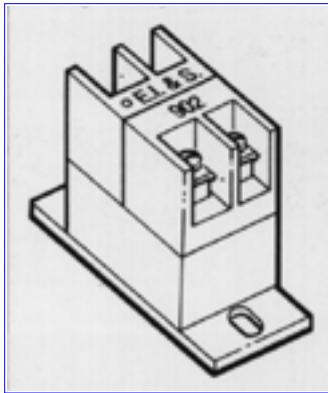

---

[Eurotherm](#) is a global organization with market leading products in industrial and process automation.



### AC or DC Input for Three Phase Applications up to 660 V at 30 A

- no heatsink required
- mounts on DIN rail or panel
- safe to the touch
- 1200-V blocking voltage
- 4000-V isolation
- zero voltage turn-on
- built-in snubber

- LED indicator

Some SSRs can have complex controllers in them; they are no longer limited to simple On/Off functions. For example, take a look at the [Eurotherm2301 Temperature Controller](#) with Integrated SSR.



[Eurotherm Controls Inc](#) announces the release of the [Eurotherm Model 2301](#), an integrated PID controller plus intelligent solid state relay. Designed for applications requiring distributed precision PID control and a high-current SSR in a single compact unit, the Model 2301 delivers. This product is ideal for SCADA, PLC, or PC-based control systems where there is a need for a PID I/O that is instantly installed and remotely supervised over a communications cable. The product contains Eurotherm's advanced self-tuning, high-speed performance, instant accuracy and trade, and patented diagnostics.

If you'd like to design your own PID controller, take a look at [Zilog's](#) application note on the subject ([http://www.zilog.com/pdfs/z8otp/pid\\_motor\\_control.pdf](http://www.zilog.com/pdfs/z8otp/pid_motor_control.pdf)).

There are typically three kinds of continuous modes of closed-loop control—proportional, integral, and derivative (or PID for short).

The control output is set depending on P, I, and D functions of the "error." Error is simply the difference between the current position (where you are) and the desired position (where you want to be).

Thus:  $\text{Output} = (P \times E) + (I \times E) + (D \times E)$

If you want to learn more about PID control, check out some of the [back issues](#) of [Circuit Cellar](#).

*Circuit Cellar Ink*, December 90/January 91, "Magnetic Levitation: An Example in Closed-Loop Control" by Jeff Bachiochi (Pronounced BAH-key-AH-key).

*Circuit Cellar Ink*, Issue #42, January 1994, "PID-Pong Challenge" by Tom Cantrell.

*Circuit Cellar Ink*, Issue #50, September 1994, "PID-Pong: Point, Set, Match: Using a Hitachi H8 for Real-time Control" by Tom Cantrell.

*Circuit Cellar Ink*, Issue #69, April 1996, "Fuzzy PID-Pong" by Tom Cantrell.

*Circuit Cellar Ink*, Issue #76, November 1996, "Self-Tuning PD Algorithm for the 68HC11" by Kenneth Baker.



[Fujitsu](#) offers four families of SSR's:

Fujitsu solid-state relays:		
File	Series #	Description
<a href="#">73k</a>	SE	Maximum load current 1.5 A/2 A, 8-pin SIP package, PCB. internal zero cross circuit type available
<a href="#">118k</a>	SG	Maximum load current 3 A, 12-pin SIP package, PCB. internal zero cross circuit type available, internal output surge absorber (varistor) type available
<a href="#">133k</a>	SJ	Maximum load current 1 A, 16-pin DIP package, PCB/socket. compatible with JY relay in size and terminal arrangement
<a href="#">140k</a>	SN	Maximum load current 1 A, 8-pin SIP package, PCB/socket. I/O modules for interface between CPU and external input devices or loads



[Grayhill I/O racks](#) are passive backplanes into which I/O modules can be installed and removed. I/O racks connect one of the logic side terminals from each module to an associated pin on the logic side connector for interface to the controller. I/O bases have an integral processor and dual port memory chip. The I/O handles scanning and storage of the I/O information which can be accessed over the bases address/data bus. Up to eight buses can be stacked along a DIN rail.



[Infineon Technologies](#) has [77 different types of SSRs](#), along with many [application notes](#) such as "[Stacking Our solid-state relays for Higher Switching Voltages](#)" (Yes, I know they spelt "Voltages" wrong, but it is the title of the document on the site). You can find a [cross reference and good general design information](#) here also.

---

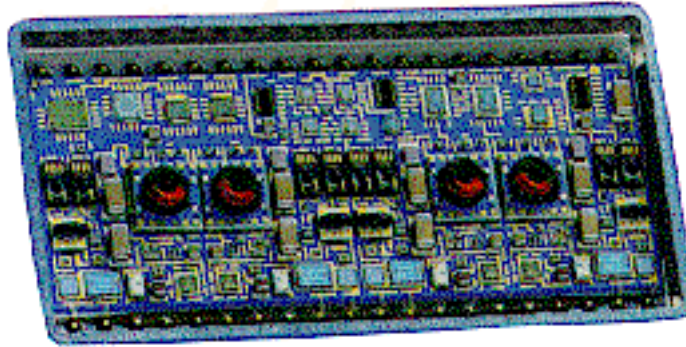

The Hybrid Division of [Micropac Industries, Inc.](#) announced their new Quad Solid-State Relay, which was designed to meet the demanding environments and critical requirements of military, air, and ground applications.

The Quad Relay is processed in a MIL-PRF-38534 qualified facility to specific MIL-STD-883 test methods. Micropac offers a wide range of custom and standard product design in solid-state relays, solid state power controllers (270 V, 115 V, and 28 V), and remote power controllers.

---



Omron has introduced an innovative new [solid state relay \(SSR\)](#) designed to prevent short circuit failure caused by external surges in the output and to ensure designers a "fail safe" condition.

The new fail safe technology developed by Omron involves precise notching of the wirebond connected to the internal die form triac (SSR output). When a damaging over current is present at the triac, the heat generated by the over current is focused on the stress notch causing it to fail at the wirebond, rather than internally within the triac. This technology results in the triac failing open or "safe," thus eliminating the need for an external fuse or protection circuitry.

In these days of allocation of every type of part, it's nice to find someone second sourcing parts. Omron's [MOSFET Relay Cross Reference](#) provides part number crosses for Aromat, CP Clare, Infineon (Siemens, AT&T), and NEC (CEL).

### [MOSFET Relay G3VM](#)

- 1 output voltage of 350–400 V
- 1 high-dielectric, 5000-VAC version available
- 1 available in PCB through-hole, SMT gullwing, and SOP terminal packages
- 1 ideal for telecom and data communications
- 1 dual relay in one package available
- current limiting option also available

## ■ TYPICAL RELAY DRIVING CIRCUIT EXAMPLES

[Go to Previous View](#)

### C-MOS

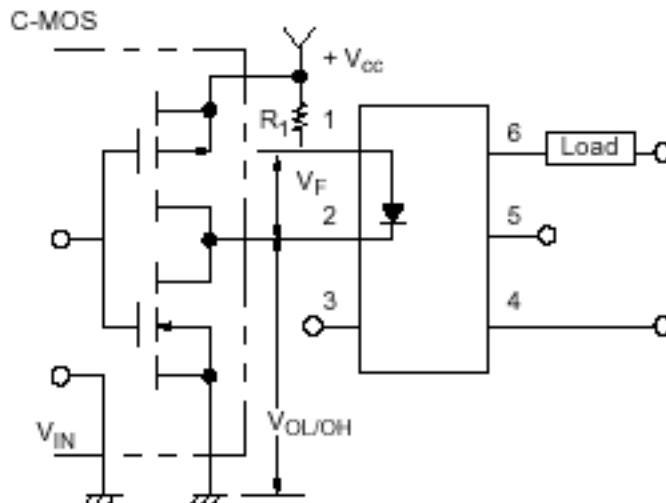

### Transistor

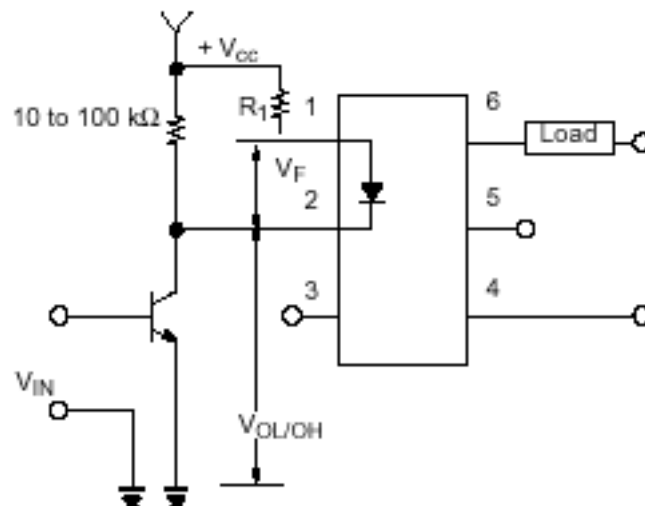

Use the following formula to obtain the LED current limiting resistance value to assure that the Relay operates accurately.

$$R_1 = \frac{V_{CC} - V_{OL} - V_F (\text{ON})}{5 \text{ to } 20 \text{ mA}}$$

Use the following formula to obtain the LED forward voltage value to assure that the Relay releases accurately.

$$V_F (\text{OFF}) = V_{CC} - V_{OH} < 0.8 \text{ V}$$

**OPTO 22**  
Connecting You to the Real World™

Opto 22 manufactures and sells electronic equipment suitable for any process control, monitoring, or data acquisition application. With hardware like the SNAP I/O® system,

Opto 22 is the world's leading supplier of reliable, flexible monitoring and control hardware.

Q: What is [Opto 22's SNAP Ethernet I/O system](#)?

A: Opto 22's SNAP Ethernet I/O system is the combination of a SNAP Ethernet brain, a mounting rack, assorted I/O or serial modules, and a power supply. With a SNAP Ethernet I/O system and an Ethernet connection, you can monitor and control both analog and digital inputs and outputs, or interface to serial devices anywhere in your facility, or anywhere else in the world. The SNAP-B3000-ENET or SNAP-ENET-D64 brains are at the heart of Opto 22's Ethernet I/O system. The SNAP Ethernet brain's built-in web server allows you to monitor your equipment in the field using only a web browser; no special software is required.

Visit [Internet I/O](#) and check out the live, hands-on demo of SNAP Ethernet I/O. For a hands-on demonstration of monitoring and controlling real-world devices over the Internet, you can connect to one of three demo stations set up at Opto 22's headquarters in Temecula, California. Each station has an Opto 22 SNAP Ethernet I/O system connected to real-world devices that you can monitor and control in real time, viewing your changes over a live web camera.

For more information on extending the reach of your IT network to include real-world devices, visit <http://www.ManagetheRealWorld.com>.

---

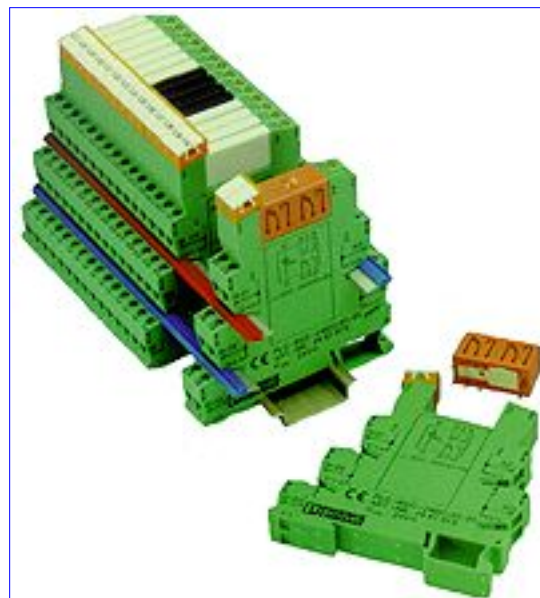

[PLC-RELAYS](#) are the latest generation of pluggable compact relay modules from [Phoenix Contact](#). The pluggable, modular, and flexible interface system offers either a relay interface (PLC-R) or a solid state relay interface (PLC-O) in a modular terminal block format in either screw clamp or spring cage connections. They consist of 6.2-mm (1/4") wide base terminal blocks and pluggable miniature relays or solid-state relays with practical switching capacities up to 6 A at 250 VAC in a single pole double throw (SPDT) configuration. A double pole double throw (DPDT) version is also available in a 14-mm (1/2") package. There is also a high current (HC) version in the 14- mm package available with practical switching capacities up to 10 A at 250 VAC.

---

[PICKER COMPONENTS CORP.](#)



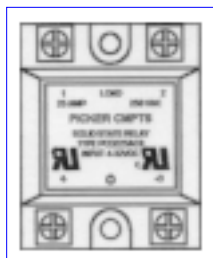

PCD Series

- 4 to 32 VDC input
- 10, 15, 25 and 40 A at 250 VAC
- Also, 25 and 40 A at 480 VAC
- Solid epoxy body
- 4,000-V isolation
- Zero crossing
- Switching
- Built-in Snubber
- Network
- High-surge resistance



[Sharp Microelectronics](#) has SSRs that range from 0.4 A/100 V to 8 A/600 V, 12 A/600 V, and just about every thing in between that you might need. Some of the units come with internal Snubbers, as well as zero crossing detection in some models. There are two [application notes](#) worth note in relation to their SSRs:

["Photocoupler, Photothyristor Coupler, and Phototriac Coupler Application Circuit"](#) (56 KB)

["Solid State Relay and Application Circuits"](#) (114 KB)



Some times you need a specialized SSR. For example, the one shown above does [silent audio switching](#). Allowing you to switch between two channels with no clicks or

pops.

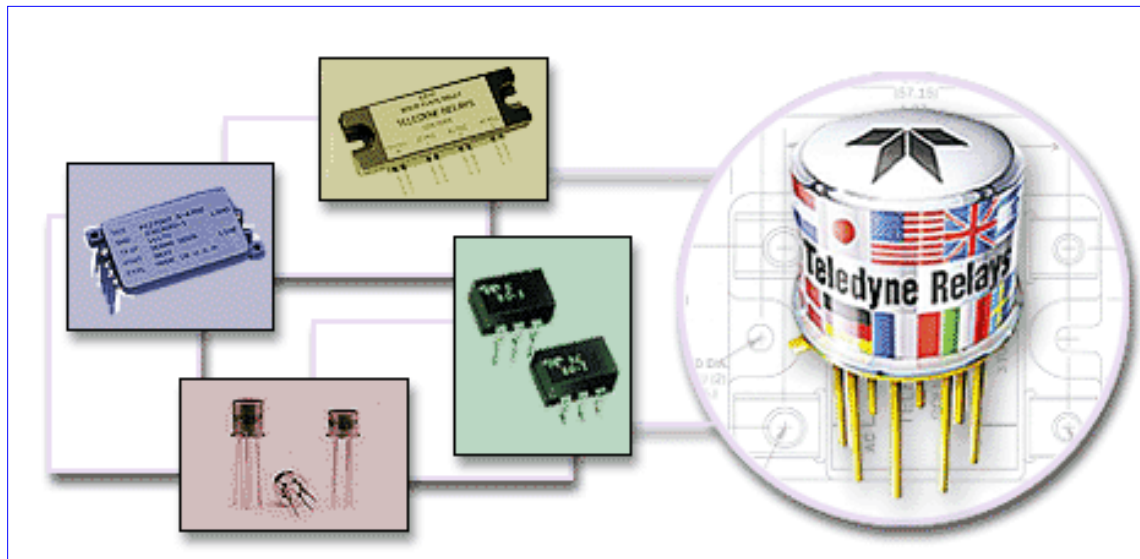

### TELEDYNE RELAYS

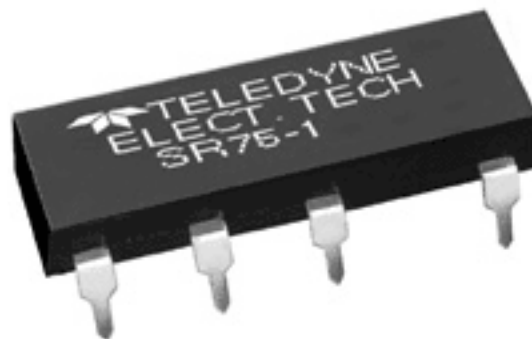

The [SR75](#) is a DC solid state relay with built-in short circuit and overload current protection. The operating voltage range is from zero to 60 VDC (SR75-1), zero to 300 VDC, or 120-Vrms AC (SR75-2) when connected with a diode bridge. This series provides protection of AC or DC loads against damage from overload currents. The SR75 offers protection against short circuit and overload currents by continuously monitoring the instantaneous load current and the output switch junction temperature. If either condition exceeds predetermined limits the relay will turn-off and remain off until it is reset by removing the overload condition and cycling the input control voltage. This action mimics a resettable circuit breaker but with a turn-off time of micro-seconds in the presence of short circuit currents. The SR75 can respond to large excess currents fast enough to prevent serious damage to the relay, system wiring, or other system components.

The related [application note](#) describes the operational considerations when using this relay and the technical benefits of the features offered.

They offer a gamut of relays from 100 mA to 200 A.

I know I missed a couple of the big names in solid-state relays here, but either their web pages were totally devoid of any data at all about their products or the site led me around in circles. I know you have better things to do with your time just as I do, than waste it on a poorly designed site.

---

---

Stop by the  
[Circuit Cellar News Server](#)  
and join some of the interesting discussion,  
or start one of your own.  
See you there...

---

**All product names and logos contained herein are the trademarks of their respective holders.**

**The fact that an item is listed here does not mean we promote its use for your application. No endorsement of the vendor or product is made or implied.**

---

*If you would like to add any information on this topic or request a specific topic to be covered, contact [Bob Paddock](#).*

---

Circuit Cellar provides up to date information for engineers, [www.circuitcellar.com](http://www.circuitcellar.com) for more information and additional articles.  
©Circuit Cellar, the Magazine for Computer Applications. Posted with permission. For subscription information, call (860) 875-2199 or e-mail [subscribe@circuitcellar.com](mailto:subscribe@circuitcellar.com)